



57HS Series Hybrid Stepping Motors

General Specifications



Step Angle Degree	1.8°
Step Angle Accuracy	±5%(full step, no load)
Temperature Rise	80°CMax
Ambient Temperature	-10°C — +50°C
Insulation Resistance	100MΩmin.500VDC
Dielectric Strength	500VAC for one minute
Shaft Radial Play	0.06 Max.(450g-load)
Shaft Axial Play	0.08 max.(450g-load)

Electrical Specifications

Model Number	Connection	Motor Length L inch (mm)	Holding Torque Oz-in (Nm)	Number of Leads	Phase Current (Amps)	Phase Resistance (Ohm)	Phase Inductance (mH)	Rotor Inertia Oz-in-sec ² (g.cm ²)	Detent Torque Oz-in (g.cm)	Weight Oz (kg)
57HS04	(Bipolar) Series	1.61 (41)	56.64 (0.4)	6	2.0	1.4±10%	1.4±20%	0.001917 (135)	-	15.87 (0.45)
	Unipolar		39.65 (0.28)		2.8	0.7±10%	0.35±20%			
57HS09	(Bipolar) Parallel	2.13 (54)	184.08 (1.3)	8	4.0	0.4±10%	1.2±20%	0.003692 (260)	5.664 (408)	21.16 (0.6)
	(Bipolar) Series		184.08 (1.3)		2.0	1.6±10%	4.8±20%			
	Unipolar		127.44 (0.9)		2.8	0.8±10%	1.2±20%			
57HS13	(Bipolar) Parallel	2.99 (76)	254.88 (1.8)	8	4.0	0.5±10%	2.1±20%	0.006532 (460)	9.912 (714)	35.27 (1.0)
	(Bipolar) Series		254.88 (1.8)		2.0	2.0±10%	8.4±20%			
	Unipolar		184.08 (1.3)		2.8	1.0±10%	2.1±20%			
57HS22	(Bipolar) Parallel	3.19 (81)	311.52 (2.2)	8	5.7	0.4±10%	1.8±20%	0.006816 (480)	-	40.57 (1.15)
	(Bipolar) Series		311.52 (2.2)		2.8	1.6±10%	7.2±20%			
	Unipolar		212.4 (1.5)		4.0	0.8±10%	1.8±20%			

* Above motors are our typical models, and if you need a customization motor, please contact us.

Mechanical Specifications (Unit=mm, 1 inch=25.4mm)

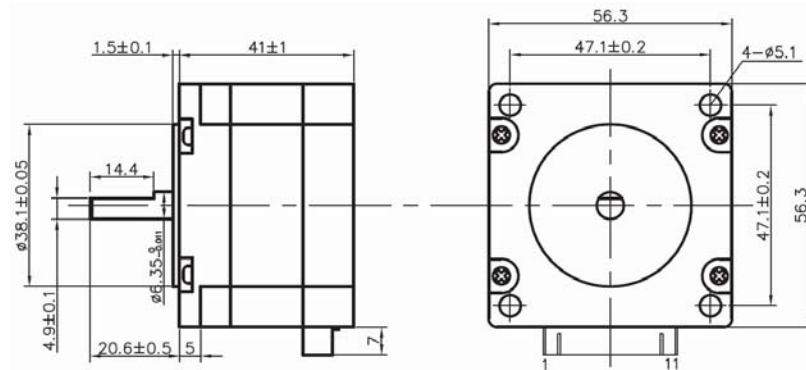

Figure 1: Mechanical specification of 57HS04

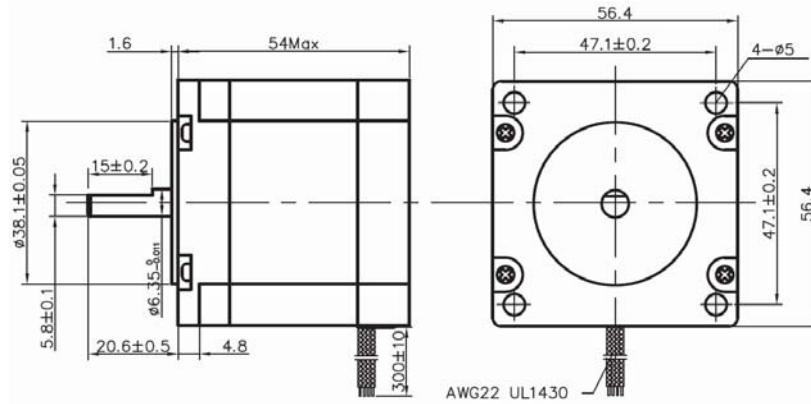

Figure 2: Mechanical specification of 57HS09

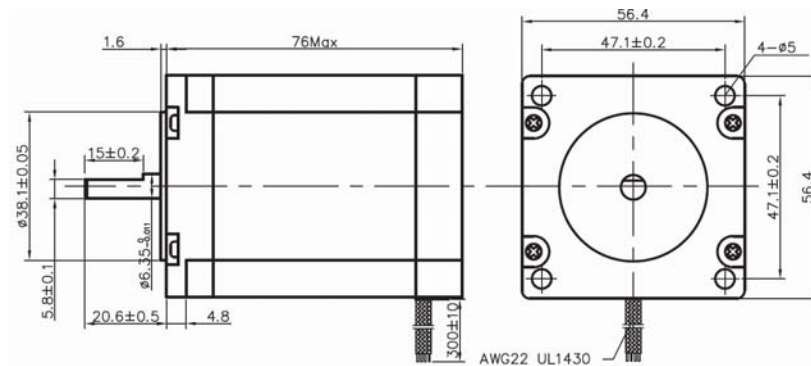

Figure 3: Mechanical specification of 57HS13

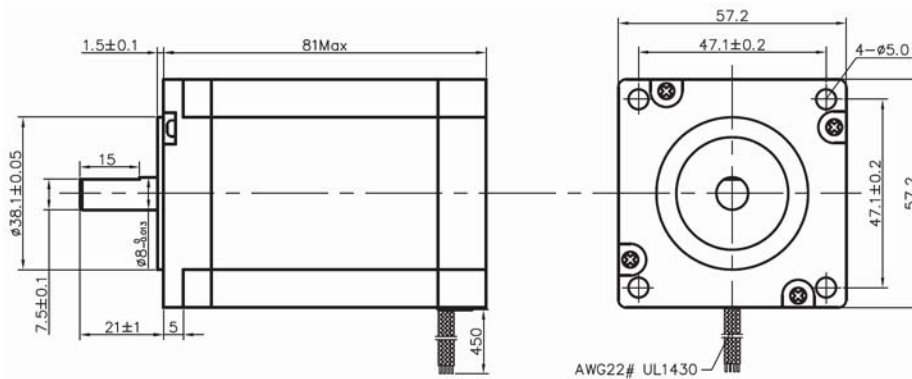
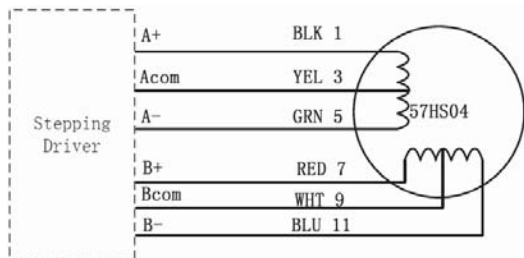
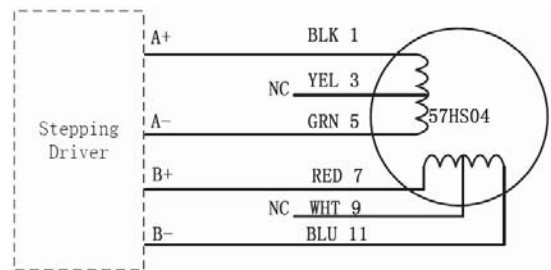

Figure 4: Mechanical specification of 57HS22

Wiring Diagrams



(a) 57HS04 unipolar connection



(b) 57HS04 bipolar (series) connection

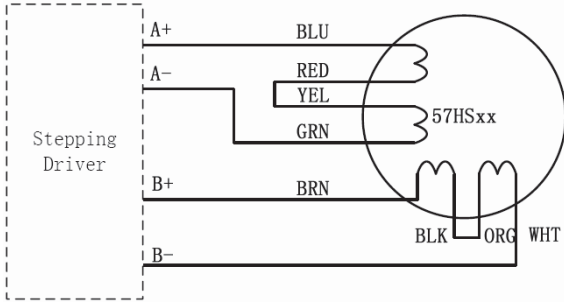

(c) 57HSxx series connection (8 leads)

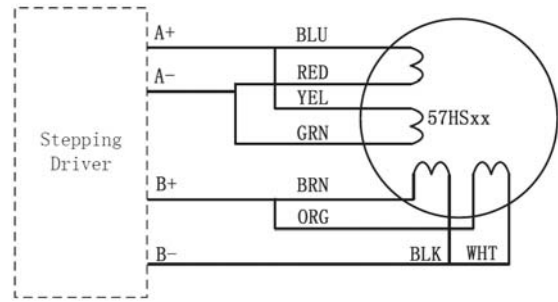

(d) 57HSxx parallel connection (8 leads)

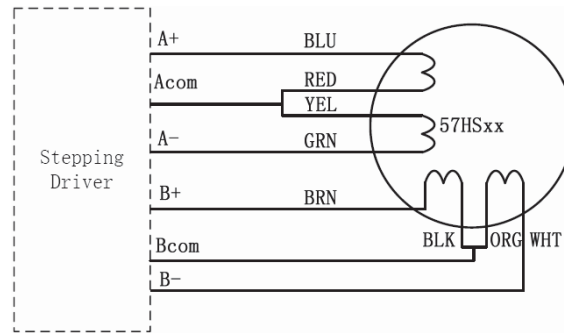

(e) 57HSxx unipolar connection (8 leads)

Figure 5: Wiring diagrams

Speed-Torque Characteristics

Unipolar and bipolar half coil, because we're using less turns, doesn't give us great low speed torque, but because of the low inductance, holds the torque out to high speeds. Bipolar series uses the full coil so it gives very good low speed torque. But because of the high inductance, the torque drops off rapidly. Bipolar parallel also uses the full coil so it gives good low speed performance. And its low inductance allows the torque to be held out to high speeds. But remember, we must increase current by 40% to get those advantages. Speed-torque curves show the maximum torques that can be output at a given speed. When selecting a motor, make sure the required torque falls within the particular curve.

• 57HS04

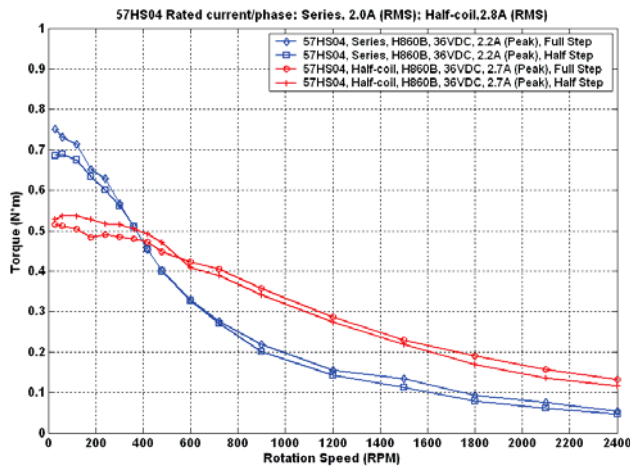

Figure 6: Speed-torque curves of the 57HS04

• 57HS09

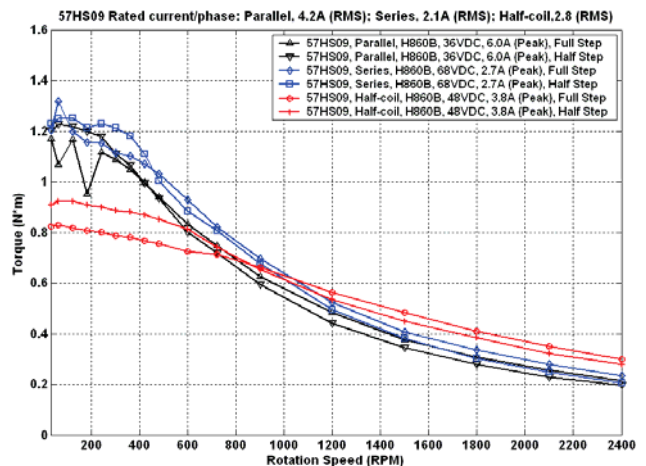

Figure 7: Speed-torque curves of the 57HS09



• 57HS13

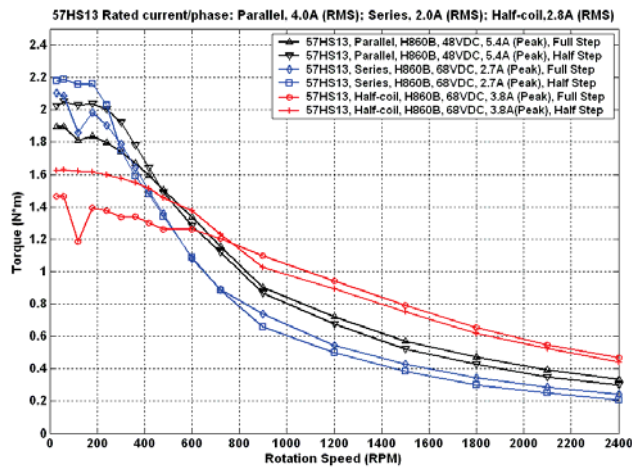

Figure 8: Speed-torque curves of the 57HS13

• 57HS22

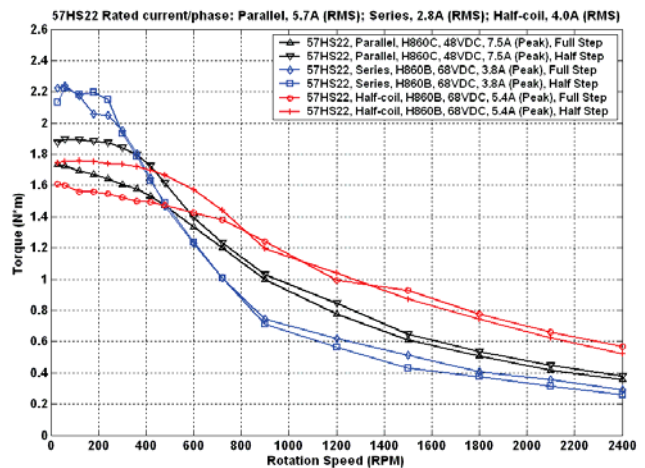

Figure 9: Speed-torque curves of the 57HS22

Remarks:

1. Title "57HS09 Rated current/phase: Parallel, 4.2A (RMS); Series, 2.1A (RMS); Half-coil, 2.8A (RMS)" means "When the 57HS09 used in parallel mode, its current/phase is 4.2A (RMS); When the 57HS09 used in series mode, its current/phase is 2.1A (RMS); When the 57HS09 used in half-coil or unipolar mode, its current/phase is 2.8A (RMS)".
2. Legend "57HS09, Parallel, H860B, 36VDC, 6.0A (Peak), Half Step" means "This speed-torque curve of the 57HS09 (connected in parallel mode) was done with the H860B driver. The settings of the H860B are 6.0A (Peak), Half Step and use 36VDC power supply".
3. The actual characteristics will vary depending on the driver used. Please use these curves only for reference purposes when selecting a motor. You must also conduct a thorough evaluation with the actual driver to be used. Please consult "Leadshine Motor and Driver Packages" for more information about this issue.